

Water Conservation - HIGH-EFFICIENCY FIXED SHOWERHEAD

High-efficiency showerheads use, on average, less than half the water of a standard showerhead while maintaining a powerful flow. This helps you save water and reduce your electricity bill without compromising the water pressure you're used to!



PRODUCT SPECIFICATIONS

Showerhead Type	Fixed
IP Thread	1/2"
Finish	Chrome
Functions	3 (full, massage, combo)
Application	Bathroom
Certification	WaterSense, UPC
Standard	ASME A112.18.1
Warranty	1 year

DETAILED DIMENSIONS

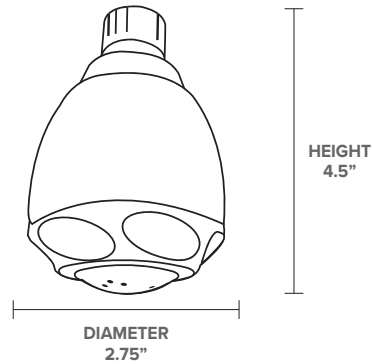

FEATURES

- Reduce your water bill by up to 40%
- 3 spray settings: full, massage, combo
- Consistent flow rate
- Compatible with the TSV adapter
- Sleek & modern chrome finish

MODEL INFORMATION

MODEL	FLOW RATE GPM	FLOW RATE LPM	MIN PSI	MAX PSI	CASE QTY
SHF/CH/3F/1.5GPM	1.5 GPM	5.7	60	80	50
SHF/CH/3F/1.75GPM	1.75 GPM	6.6	20	60	50

1-877-255-0004 | info@greenliteusa.com

www.greenliteusa.com

V1-121124

