

LED Fixtures - DUSK-TO-DAWN NITE LITE

Automatic light-sensing technology for enhanced safety and convenience. Save energy and enjoy reliable illumination in hallways, stairwells, and more.



PRODUCT SPECIFICATIONS

Wattage	0.3W
Lumens	5LM
Lifetime	25,000 hours
Function	Dusk to Dawn
Color Temperature	3000K
LED Model	2835
Ra/CRI	80
Beam Angle	110°
Control	CDS
Material	PC + ABS
Certifications	ETL/CETL
Warranty	2 years

DETAILED DIMENSIONS

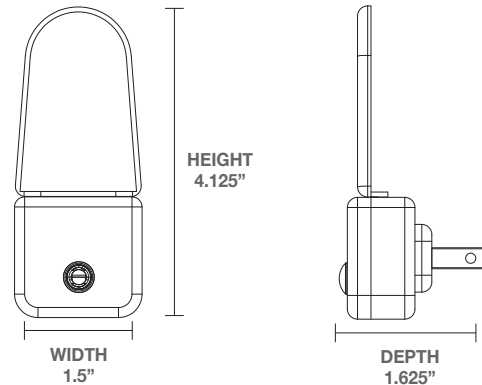

FEATURES

- OFF in the day, ON at night
- Dusk-to-dawn sensor
- Added safety and security
- Cool-to-touch
- Shatterproof lens

MODEL INFORMATION

MODEL NUMBER	PACK SIZE	CASE QTY
NL/CLEAR/DD	1	50
NL/CLEAR/DD/2	2	48

1-877-255-0004 | info@greenliteusa.com

www.greenliteusa.com

V1-012325

