

Air Quality and Home Safety - COMBINATION SMOKE AND CO DETECTOR

This combination smoke and CO detector offers reliable and low-maintenance safety. Dual sensors provide comprehensive protection with a loud 85dB alarm, while the 10-year lifespan and easy installation minimize upkeep. ETL listed and UL compliant for quality assurance, this detector offers long-term value and peace of mind.



PRODUCT SPECIFICATIONS

Product Type	Combination Smoke and CO detector
Power Source	2 x AA batteries
Sensor	Photoelectric & Electrochemical
Alarm Volume	≥85dB@10ft
Battery Lifetime	>1 Year
Product Lifetime	10 Years
Alarm Mode	Sound and red LED signal
Temperature Range	40°F (4.4°C) to 100°F (37.8°C)
Humidity Range	10%-95% relative humidity, non-condensing
Mounting Type	Wall mount or ceiling mount
Unit Weight	305g (including battery)
Warranty	3 Year product limited
Standard	ETL, CONFORMS TO UL STD 217 AND UL STD 2034

DETAILED DIMENSIONS

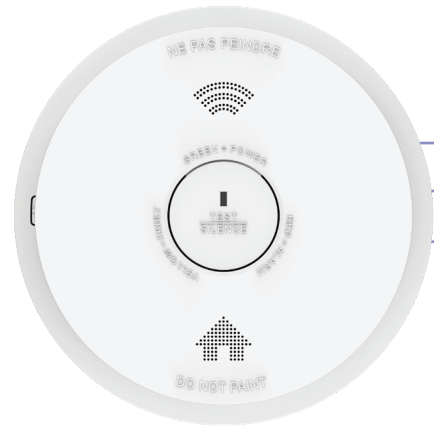
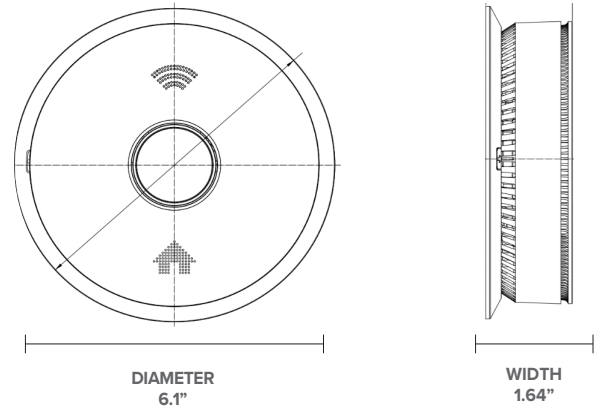

FEATURES

- Dual sensors for smoke & CO detection
- 10-year product life for long-term value and minimal replacement costs
- Easy installation and over 1-year battery life

MODEL INFORMATION

MODEL	CASE QTY

1-877-255-0004 | info@greenliteusa.com

www.greenliteusa.com

V1 - 20250120

