

Air Quality and Home Safety - 22 PINT DEHUMIDIFIER

Greenlite's 22-Pint Dehumidifier improves indoor comfort, protects against mold and moisture damage, and supports utility program goals for healthier, more efficient homes. With simple digital controls, easy bucket access, and a continuous drain option, it delivers dependable humidity control in high-moisture areas and is effortless for customers to operate and maintain.



PRODUCT SPECIFICATIONS

Product Type	Portable Dehumidifier
Power Supply	115V_1Ph; 2.2 A
Input Wattage	250W
Dehumidifier Water Removal Capacity	22 pints/day
Integrated Energy Factor	1.7/L/kWh
Annual Energy Consumption	276 (kWh/year)
Refrigerant Type	HFC-32 (R32)
Refrigerant Charge (ounces)	3.53 oz
Coverage Area	Up to 1,500 sq. ft.
Maximum Noise Level	50 dB(A)
Bucket Size (Liters)	3.2L

DETAILED DIMENSIONS

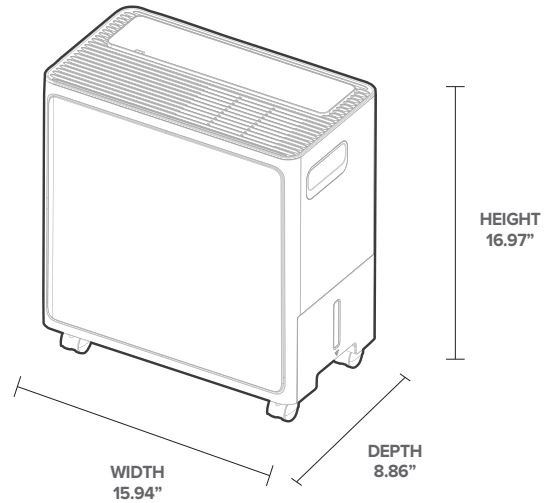

FEATURES

- Removes up to 22 pints of moisture daily
- Continuous drain option for hassle-free operation
- Easy digital controls with adjustable humidistat
- Energy Star certified for efficient performance



Air Quality and Home Safety - 22 PINT DEHUMIDIFIER

Color	White
Fan Speed	2 (Low -> High)
Operation Modes	4 Modes: Dehumidifier, Comfort, Dryer, Continuous
Humidity Set Control	35% to 85%
Filter Type	Removable
Clean Filter Indicator Light	Yes
Bucket Fill Indicator	Yes
Automatic Shutoff	Yes
Automatic Defrost Control	Yes
TIMER Set Control	Yes
Manufacturer Warranty	1 Year
Certifications	Energy Star, UL
Unit Weight	30.86 lbs



MODEL INFORMATION

MODEL	CASE QTY
GL-DEH22R32	1