



Model NO. 17W/T8/4B/35K/DE

# 17W LED T8 Linear Tube Ballast Bypass - Double Ended

## INSTALLATION GUIDE – WARNING

**WARNING** - Risk of fire or electric shock. LED Retrofit Kit installation requires knowledge of luminaire electrical systems. Installation should be performed only by a qualified **electrician in accordance with the National Electrical Code and relevant local code.**

**WARNING** - Risk of fire or electric shock. Install this kit only in the luminaires that have the construction features and dimensions shown in the photographs and/or drawings.

**WARNING** - To prevent wiring damage or abrasion, do not expose wiring to edges of sheet metal or other **sharp objects.**

**WARNING** - Risk of fire or electric shock. Luminaire wiring and electrical parts may be damaged when drilling for installation of LED retrofit kit. Check for enclosed wiring and components.

- Disconnect power at the source before installation, inspection or removal. Do not simply switch off fixture.
- This item is rated at 120-277V. Installer must determine whether line voltage 120-277V is available at the luminaire before installation.
- Not intended for use with emergency exit fixtures or emergency exit lights.
- Not for use with luminaire ballast.
- Do not use if product is damaged.
- This lamp is non-dimmable. Not for use with dimmers.
- Suitable for use with non-shunted and shunted lamp holders.
- Do not make or alter any open holes in an enclosure of wiring or electrical components during kit installation.
- "This luminaire has been modified to operate LED lamps" shall be marked on the retrofit luminaire where readily visible by the user during normal maintenance including re-lamping.
- Risk of fire or electric shock. Do not open or modify. No user serviceable parts inside.
- Installers should not disconnect existing wires from lamp holder terminals to make new connections at lamp holder terminals. Instead installers should cut existing lamp holder leads away from the lamp holder and make new electrical connections to lamp holder lead wires by employing applicable connectors.
- **SUITABLE FOR DAMP LOCATIONS.** Suitable for use in wet locations when used in an outdoor-rated fixture. Not for use where directly exposed to the weather or water.
- Complies with Part 15 of FCC. Operation is subject to the following two conditions: (1) This device may not cause harmful interference, and (2) This device must accept any interference received including interference that may cause undesired operation.
- **SUITABLE FOR "TYPE IC" OR "TYPE NON-IC" LUMINAIRES.**
- No external weight or mechanical force should be applied to tube or components.
- **THE RETROFIT ASSEMBLY IS ACCEPTED AS A COMPONENT OF A LUMINAIRE WHERE THE SUITABILITY OF THE COMBINATION SHALL BE DETERMINED BY UL OR AUTHORITIES HAVING JURISDICTION.**
- The lamps are intended to retrofit surface mount, Type IC or non-IC recessed mount listed fluorescent luminaires that use maximum 4 tubular lamps.

**LIMITED WARRANTY:** This product is warranted to be free from defects in workmanship and material for 5 years. If it fails to do so, Greenlite™ will send you, at its election, a replacement product or refund your original purchase price upon receipt of the returned fixture, register receipt and proof of purchase. Please call (844) 695-9090 to find out how to return the product. Do not return this product to the retailer. This limited warranty does not cover product subject to accident, neglect, abuse, misuse or acts of God. Replacement or refund is your sole remedy.

For all enquiries, please contact our customer service team at  
[info@greenliteusa.com](mailto:info@greenliteusa.com) or 1-844-695-9090 from 9:00 AM to 5:00 PM EST.

[www.greenliteusa.com](http://www.greenliteusa.com)  
V1-11/01/2021

Model NO. 17W/T8/4B/35K/DE

# 17W LED T8 Linear Tube Ballast Bypass - Double Ended

## LED TUBE INSTALLATION GUIDE

- 1) Read all WARNINGS before continuing this section.
- 2) Make sure POWER IS TURNED OFF at the source to the location at which you are installing the product.
- 3) Remove lens, cover and fluorescent tubes. Cut away all wires connecting the ballast. (fig. 1)
- 4) Make sure to connect the line (L) and neutral (N) to the corresponding ends of the tube marked L and N. Note this product is double-ended, do not wire to a single end. (fig. 2)
- 5) Follow wiring diagrams for number of lamps and original ballast type (instant start, programmed start or rapid start). (fig. 3-6)
- 6) Visibly affix the "Modification Sticker" to the fixture and reinstall housing cover and lens if applicable.
- 7) Return power back to the source and installation is complete.

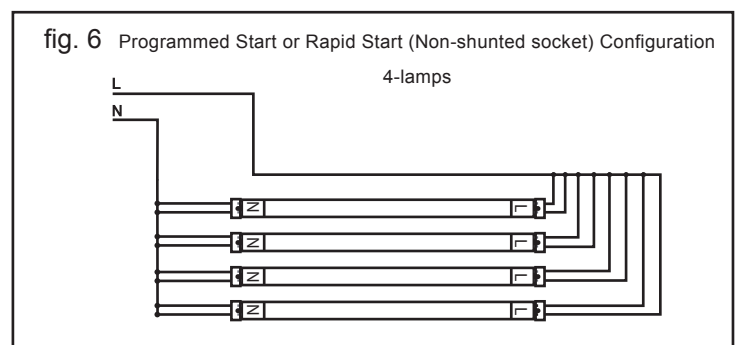
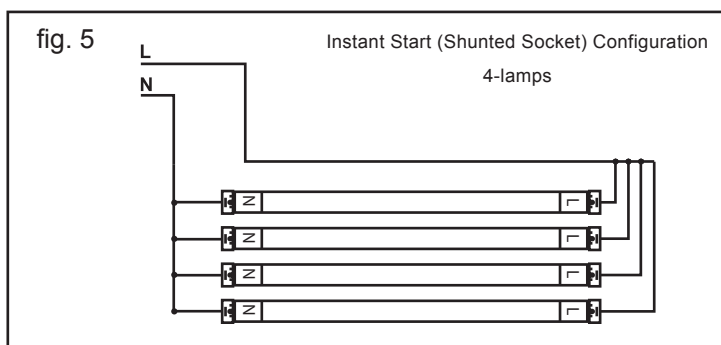
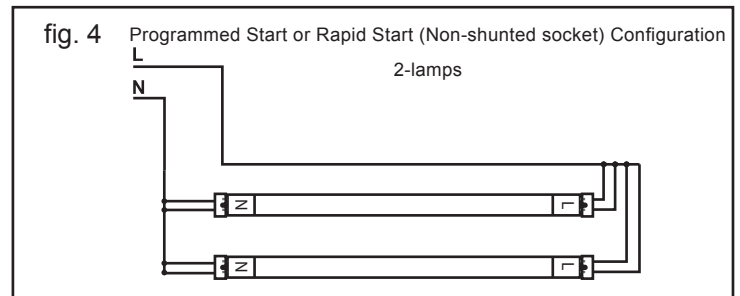
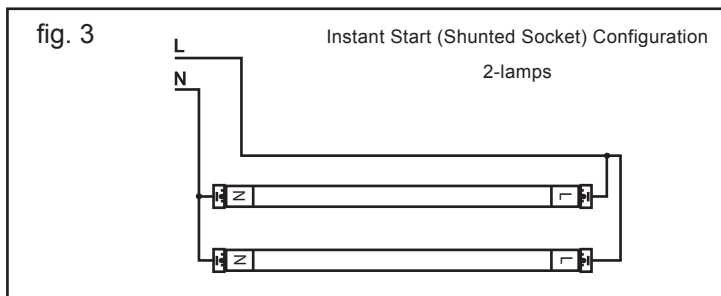
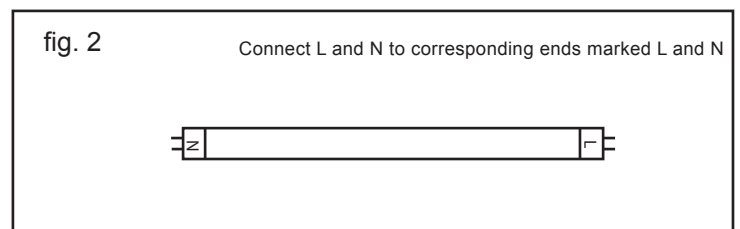
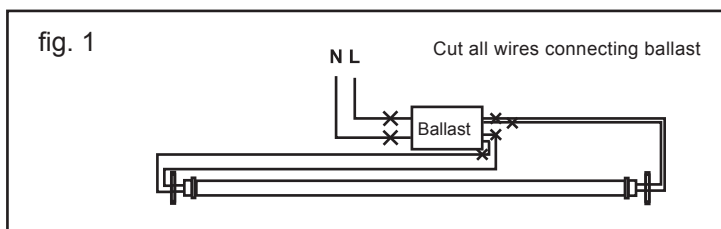

**LIMITED WARRANTY:** This product is warranted to be free from defects in workmanship and material for 5 years. If it fails to do so, Greenlite™ will send you, at its election, a replacement product or refund your original purchase price upon receipt of the returned fixture, register receipt and proof of purchase. Please call (844) 695-9090 to find out how to return the product. Do not return this product to the retailer. This limited warranty does not cover product subject to accident, neglect, abuse, misuse or acts of God. Replacement or refund is your sole remedy.